

Inserts

**CQ 5 poles + ⊕ 16A - 230/400V**

enclosures:  
size "21.21" page:

Insulating type	339 - 348
Metallic type	349 - 363
W-TYPE for aggressive environments	512 - 518
EMC	564 - 572
IP68	628 - 631
E-Xtreme® corrosion proof	538 - 539

- it is recommended to crimp the contacts with crimping tools homologated by ILME (please see the crimping tool section 16A contacts, CCF, CCM and CC...AN series on pages 708 - 741)
- inserts and enclosures for applications with temperatures up to 180 °C, available on request
- can also be used partially fitted with 4 mm<sup>2</sup> section contacts

inserts, crimp connections



16A crimp contacts  
standard or for advanced opening  
silver and gold plated

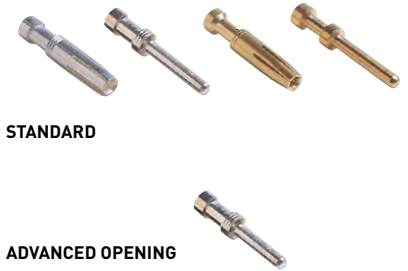

STANDARD

ADVANCED OPENING

description	part No.	part No.
-------------	----------	----------

without contacts (to be ordered separately)  
female inserts for female contacts  
male inserts for male contacts

**CQF 05**  
**CQM 05**

16A female contacts

0,14-0,37 mm <sup>2</sup>	AWG 26-22	one groove
0,5 mm <sup>2</sup>	AWG 20	with no grooves
0,75 mm <sup>2</sup>	AWG 18	one groove (back side)
1 mm <sup>2</sup>	AWG 18	one groove
1,5 mm <sup>2</sup>	AWG 16	two grooves
2,5 mm <sup>2</sup>	AWG 14	three grooves
3 mm <sup>2</sup>	AWG 12	one wide groove
4 mm <sup>2</sup>	AWG 12	with no grooves

16A male contacts

0,14-0,37 mm <sup>2</sup>	AWG 26-22	one groove
0,5 mm <sup>2</sup>	AWG 20	with no grooves
0,75 mm <sup>2</sup>	AWG 18	one groove (back side)
1 mm <sup>2</sup>	AWG 18	one groove
1,5 mm <sup>2</sup>	AWG 16	two grooves
2,5 mm <sup>2</sup>	AWG 14	three grooves
3 mm <sup>2</sup>	AWG 12	one wide groove
4 mm <sup>2</sup>	AWG 12	with no grooves

16A male crimp contacts for advanced opening

0,5 mm <sup>2</sup>	AWG 20	with no grooves
0,75 mm <sup>2</sup>	AWG 18	one groove (back side)
1 mm <sup>2</sup>	AWG 18	one groove
1,5 mm <sup>2</sup>	AWG 16	two grooves
2,5 mm <sup>2</sup>	AWG 14	three grooves

CCFA 0.3  
CCFA 0.5  
CCFA 0.7  
CCFA 1.0  
CCFA 1.5  
CCFA 2.5  
CCFA 3.0  
CCFA 4.0

silver plated

CCFD 0.3  
CCFD 0.5  
CCFD 0.7  
CCFD 1.0  
CCFD 1.5  
CCFD 2.5  
CCFD 3.0  
CCFD 4.0

gold plated\*

CCMA 0.3  
CCMA 0.5  
CCMA 0.7  
CCMA 1.0  
CCMA 1.5  
CCMA 2.5  
CCMA 3.0  
CCMA 4.0

CCMD 0.3  
CCMD 0.5  
CCMD 0.7  
CCMD 1.0  
CCMD 1.5  
CCMD 2.5  
CCMD 3.0  
CCMD 4.0

CC 0.5 AN  
CC 0.7 AN  
CC 1.0 AN  
CC 1.5 AN  
CC 2.5 AN

\* for basic or high thickness gold plating, please refer to page 675

- characteristics according to EN 61984:

**16A 230/400V 4kV 3**  
**16A 320/500V 4kV 2**

- cULus (UL for USA and Canada),

- certified
- rated voltage according to UL/CSA: 600V
- insulation resistance: ≥ 10 GΩ
- ambient temperature limit: -40 °C ... +125 °C
- made of self-extinguishing thermoplastic resin UL 94V-0
- mechanical life: ≥ 500 cycles
- contact resistance: ≤ 1 mΩ
- for max. current load see the connector inserts derating diagram below; for more information see page 28

**CQ 05 poles connector inserts**  
**Maximum current load derating diagram**

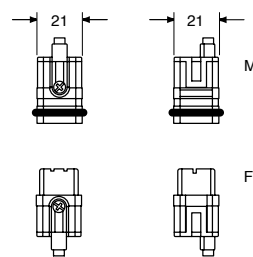
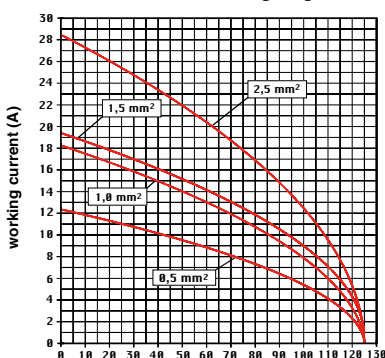

contacts side (front view)

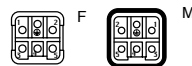

**Note:**  
PE screw connection for unprepared wires only

**Coding pins CR CPQ**  
(page 689)



CCF and CCM

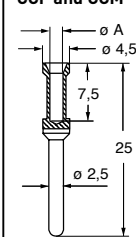

CC...AN

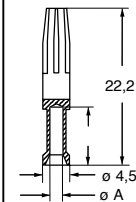
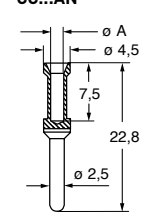

**CCF, CCM and CC...AN contacts**

conductor section mm <sup>2</sup>	conductor slot ø A (mm)	conductors stripping length (mm)
0,14-0,37	0,9	7,5
0,5	1,1	7,5
0,75	1,3	7,5
1,0	1,45	7,5
1,5	1,8	7,5
2,5	2,2	7,5
3	2,55	7,5
4	2,85	7,5

# CQ 7 poles + ⊕ 10A - 400V

enclosures: size "21.21"	page:
Insulating type	339 - 348
Metallic type	349 - 363
W-TYPE for aggressive environments	512 - 518
EMC	564 - 572
IP68	628 - 631
E-Xtreme® corrosion proof	538 - 539

inserts, crimp connections



10A crimp contacts  
silver and gold plated



description	part No.	part No
-------------	----------	---------

without contacts (to be ordered separately)  
 female inserts for female contacts **CQF 07**  
 male inserts for male contacts **CQM 07**

<b>10A female contacts</b>		
0,14-0,37 mm <sup>2</sup>	AWG 26-22	identification No. 1
0,5 mm <sup>2</sup>	AWG 20	identification No. 2
0,75 mm <sup>2</sup>	AWG 18	identification No. ②
1 mm <sup>2</sup>	AWG 18	identification No. 3
1,5 mm <sup>2</sup>	AWG 16	identification No. 4
2,5 mm <sup>2</sup>	AWG 14	identification No. 5
<b>10A male contacts</b>		
0,14-0,37 mm <sup>2</sup>	AWG 26-22	identification No. 1
0,5 mm <sup>2</sup>	AWG 20	identification No. 2
0,75 mm <sup>2</sup>	AWG 18	identification No. ②
1 mm <sup>2</sup>	AWG 18	identification No. 3
1,5 mm <sup>2</sup>	AWG 16	identification No. 4
2,5 mm <sup>2</sup>	AWG 14	identification No. 5

silver plated	gold plated+
<b>CDFA 0.3</b>	<b>CDFD 0.3</b>
<b>CDFA 0.5</b>	<b>CDFD 0.5</b>
<b>CDFA 0.7</b>	<b>CDFD 0.7</b>
<b>CDFA 1.0</b>	<b>CDFD 1.0</b>
<b>CDFA 1.5</b>	<b>CDFD 1.5</b>
<b>CDFA 2.5</b>	<b>CDFD 2.5</b>
<b>CDMA 0.3</b>	<b>CDMD 0.3</b>
<b>CDMA 0.5</b>	<b>CDMD 0.5</b>
<b>CDMA 0.7</b>	<b>CDMD 0.7</b>
<b>CDMA 1.0</b>	<b>CDMD 1.0</b>
<b>CDMA 1.5</b>	<b>CDMD 1.5</b>
<b>CDMA 2.5</b>	<b>CDMD 2.5</b>

- characteristics according to EN 61984:  
**10A 400V 6kV 3**
- (UL for USA and Canada),
- **ERC** certified
- rated voltage according to UL/CSA: 600V
- insulation resistance: ≥ 10 GΩ
- ambient temperature limit: -40 °C ... +125 °C
- made of self-extinguishing thermoplastic resin UL 94V-0
- mechanical life: ≥ 500 cycles
- contact resistance: ≤ 3 mΩ
- inserts already supplied with stainless steel fixing screw with gasket, which ensures IP66/IP67/IP69 degree of protection
- first-make last-break screw-type PE contact
- **it is recommended to crimp the contacts with crimping tools homologated by ILME** (please see the crimping tool section 10A contacts, CDF and CDM series on pages 708 - 741)
- for max. current load see the connector inserts derating diagram below; for more information see page 28

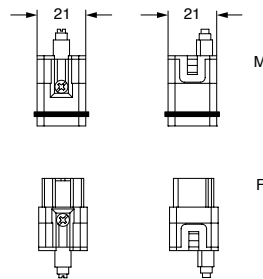

contacts side (front view)



**Note:**  
PE screw connection for unprepared wires only

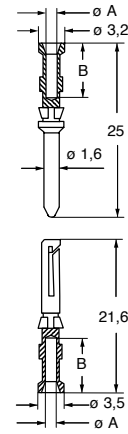

**CDF and CDM contacts**

conductor section mm <sup>2</sup>	conductor ø A (mm)	conductors stripping length B (mm)
0,14-0,37	0,9	8
0,5	1,1	8
0,75	1,3	8
1,0	1,45	8
1,5	1,8	8
2,5	2,2	6

**CQ 07 poles connector inserts**  
Maximum current load derating diagram

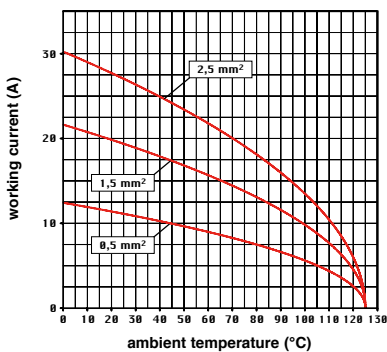

The **CR QF07** and **CR QM07** coding pins (to be ordered separately), allow the user to create 6 different combinations, according to the diagram shown on **page 690**



† for basic or high thickness gold plating, please refer to page 674

# CQ 12 poles + ⊕ series

## TECHNICAL FEATURES

### Compactness meets performance

Compact solution for high density needs.

Reliable, 16 coding possibilities, perfect for small motors with bridges for star/delta configuration.

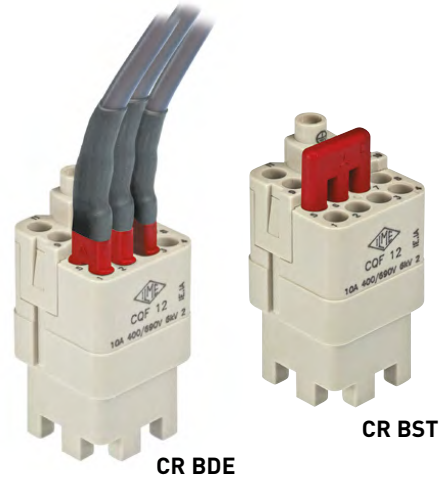

Bridges for delta or star connection  
from page 694, 695

### Coding positions for CQ 12 connector

See diagram to the right

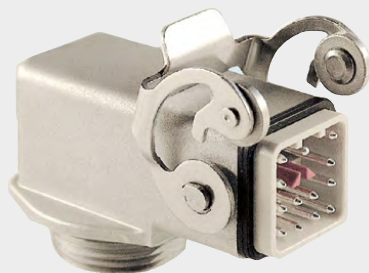

**Legend:**

- (A B) CQ 12 coding pin
- M = male insert
- F = female insert

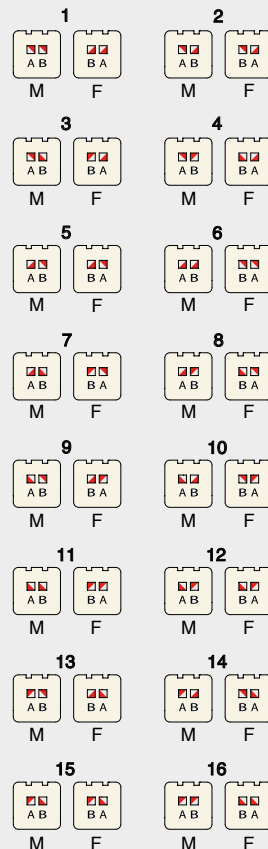

# CQ 12 poles + ⊕ 10A - 400V

enclosures: size "21.21"	page:
Insulating type	339 - 348
Metallic type	349 - 363
W-TYPE for aggressive environments	512 - 518
EMC	564 - 572
IP68	628 - 631
E-Xtreme® corrosion proof	538 - 539



ISO 23570-3 standard and  
DESINA, specification  
compliant

## inserts, crimp connections



## 10A crimp contacts silver and gold plated



description	part No.	part No
-------------	----------	---------

without contacts (to be ordered separately)  
female inserts for female contacts  
male inserts for male contacts

**CQF 12**  
**CQM 12**

10A female contacts		
0,14-0,37 mm <sup>2</sup>	AWG 26-22	identification No. 1
0,5 mm <sup>2</sup>	AWG 20	identification No. 2
0,75 mm <sup>2</sup>	AWG 18	identification No. ②
1 mm <sup>2</sup>	AWG 18	identification No. 3
1,5 mm <sup>2</sup>	AWG 16	identification No. 4
2,5 mm <sup>2</sup>	AWG 14	identification No. 5
10A male contacts		
0,14-0,37 mm <sup>2</sup>	AWG 26-22	identification No. 1
0,5 mm <sup>2</sup>	AWG 20	identification No. 2
0,75 mm <sup>2</sup>	AWG 18	identification No. ②
1 mm <sup>2</sup>	AWG 18	identification No. 3
1,5 mm <sup>2</sup>	AWG 16	identification No. 4
2,5 mm <sup>2</sup>	AWG 14	identification No. 5

CDFA 0.3 CDFA 0.5 CDFA 0.7 CDFA 1.0 CDFA 1.5 CDFA 2.5	silver plated	CDFD 0.3 CDFD 0.5 CDFD 0.7 CDFD 1.0 CDFD 1.5 CDFD 2.5	gold plated+
CDMA 0.3 CDMA 0.5 CDMA 0.7 CDMA 1.0 CDMA 1.5 CDMA 2.5		CDMD 0.3 CDMD 0.5 CDMD 0.7 CDMD 1.0 CDMD 1.5 CDMD 2.5	

- characteristics according to EN 61984:  
**10A 400V 6kV 3**  
**10A 400/690V 6kV 2**
- certified
- rated voltage according to UL/CSA: 600V
- insulation resistance: ≥ 10 GΩ
- ambient temperature limit: -40 °C ... +125 °C
- made of self-extinguishing thermoplastic resin UL 94V-0
- mechanical life: ≥ 500 cycles
- contact resistance: ≤ 3 mΩ
- inserts already supplied with stainless steel fixing screw with gasket, which ensures IP66/IP67/IP69 degree of protection
- **it is recommended to crimp the contacts with crimping tools homologated by ILME** (please see the crimping tool section 10A contacts, CDF and CDM series on pages 708 - 741)
- for max. current load see the connector inserts derating diagram below; for more information see page 28

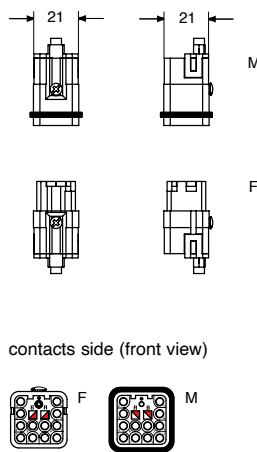

contacts side (front view)

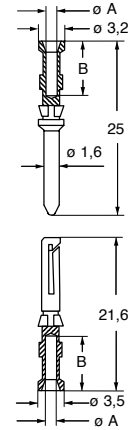

### CDF and CDM contacts

conductor section	conductor ø A (mm)	conductors stripping length B (mm)
0,14-0,37	0,9	8
0,5	1,1	8
0,75	1,3	8
1,0	1,45	8
1,5	1,8	8
2,5	2,2	6

**CQ 12 poles connector inserts**  
**Maximum current load derating diagram**

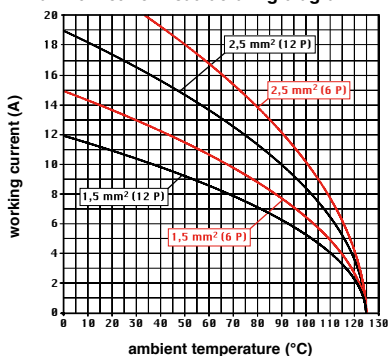

**Note:**  
PE screw connection for unprepared wires only

☑ The CR Q12 coding pins (to be ordered separately), allow the user to create 16 different combinations, according to the diagram shown on **page 689**



† for basic or high thickness gold plating, please refer to page 674

Inserts

**CQ 21 poles 6,5A - 50V ac / 120V dc**

enclosures: size "21.21"	page:
Insulating type	339 - 348
Metallic type	349 - 363
W-TYPE for aggressive environments	512 - 518
EMC	564 - 572
IP68	628 - 631
E-Xtreme® corrosion proof	538 - 539

inserts, crimp connections



CI crimp contacts  
silver and gold plated



CQ

description	part No.	part No.
-------------	----------	----------

without contacts (to be ordered separately)  
female inserts for female contacts  
male inserts for male contacts

**CQF 21**  
**CQM 21**

CI female crimp contacts  
0,08-0,21 mm<sup>2</sup> AWG 28-24  
0,13-0,33 mm<sup>2</sup> AWG 26-22  
0,33-0,52 mm<sup>2</sup> AWG 22-20

**CIFA 0.2**  
**CIFA 0.3**  
**CIFA 0.5**

silver plated

**CIFD 0.2**  
**CIFD 0.3**  
**CIFD 0.5**

gold plated

CI male crimp contacts  
0,08-0,21 mm<sup>2</sup> AWG 28-24  
0,13-0,33 mm<sup>2</sup> AWG 26-22  
0,33-0,52 mm<sup>2</sup> AWG 22-20

**CIMA 0.2**  
**CIMA 0.3**  
**CIMA 0.5**

**CIMD 0.2**  
**CIMD 0.3**  
**CIMD 0.5**

- characteristics according to EN 61984:  
**6,5A 50V ac / 120V dc 0,8kV 3**
- (UL for USA and Canada), certified
- rated voltage according to UL/CSA: 250V
- insulation resistance: ≥ 10 GΩ
- ambient temperature limit: -40 °C ... +125 °C
- made of self-extinguishing thermoplastic resin  
UL 94V-0
- mechanical life: ≥ 500 cycles
- contact resistance: ≤ 4 mΩ
- seat of contact #9 on both inserts set forward to obtain  
pre-leading contact (e.g. for FE functional earth)
- for crimp contacts CI series use, see page 716 - 719  
**CIPZ D** crimping tool  
**CITP D** turret head  
**CIES** insertion / removal tool
- for max. current load see the connector inserts derating  
diagram below; for more information see page 28

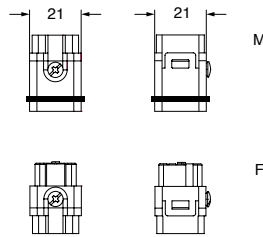

contacts side (front view)

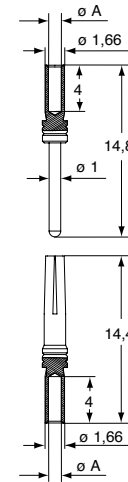

**CI and CIM contacts**

conductor section mm <sup>2</sup>	conductor slot ø A (mm)	conductors stripping length (mm)
0,08-0,21	0,64	4
0,13-0,33	0,90	4
0,33-0,52	1,12	4

max insulation diameter: 1,7 mm

**CQ 21 poles connector inserts**  
**Maximum current load derating diagram**

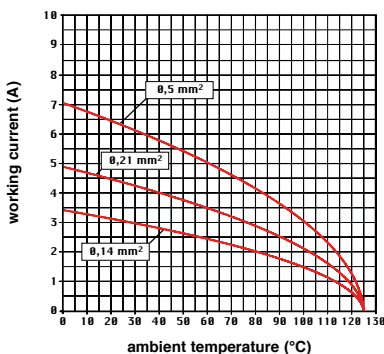

# CQ 4 poles (40A - 400/690V) + 2 poles (10A - 250V) + ⊕

enclosures:  
size "32.13"

page:

insulating type  
EMC

365 - 367  
573 - 574

ISO 23570-3 standard and  
DESINA, specification  
compliant



inserts, crimp connections



40A and 10A crimp contacts  
silver and gold plated



description	part No.	part No
-------------	----------	---------

without contacts (to be ordered separately)  
female inserts for female contacts  
male inserts for male contacts

**CQF 04/2**  
**CQM 04/2**

40A female crimp contacts  
1,5 mm<sup>2</sup> AWG 16  
2,5 mm<sup>2</sup> AWG 14  
4 mm<sup>2</sup> AWG 12  
6 mm<sup>2</sup> AWG 10

**CXFA 1.5**  
**CXFA 2.5**  
**CXFA 4.0**  
**CXFA 6.0**

silver plated

\* for basic or high  
thickness gold  
plating, please refer  
to page 674

40A male crimp contacts  
1,5 mm<sup>2</sup> AWG 16  
2,5 mm<sup>2</sup> AWG 14  
4 mm<sup>2</sup> AWG 12  
6 mm<sup>2</sup> AWG 10

**CXMA 1.5**  
**CXMA 2.5**  
**CXMA 4.0**  
**CXMA 6.0**

10A female contacts

0,14-0,37 mm <sup>2</sup>	AWG 26-22	identification No. 1
0,5 mm <sup>2</sup>	AWG 20	identification No. 2
0,75 mm <sup>2</sup>	AWG 18	identification No. ②
1 mm <sup>2</sup>	AWG 18	identification No. 3
1,5 mm <sup>2</sup>	AWG 16	identification No. 4
2,5 mm <sup>2</sup>	AWG 14	identification No. 5

**CDFA 0.3**  
**CDFA 0.5**  
**CDFA 0.7**  
**CDFA 1.0**  
**CDFA 1.5**  
**CDFA 2.5**

gold plated+

**CDFD 0.3**  
**CDFD 0.5**  
**CDFD 0.7**  
**CDFD 1.0**  
**CDFD 1.5**  
**CDFD 2.5**

10A male contacts

0,14-0,37 mm <sup>2</sup>	AWG 26-22	identification No. 1
0,5 mm <sup>2</sup>	AWG 20	identification No. 2
0,75 mm <sup>2</sup>	AWG 18	identification No. ②
1 mm <sup>2</sup>	AWG 18	identification No. 3
1,5 mm <sup>2</sup>	AWG 16	identification No. 4
2,5 mm <sup>2</sup>	AWG 14	identification No. 5

**CDMA 0.3**  
**CDMA 0.5**  
**CDMA 0.7**  
**CDMA 1.0**  
**CDMA 1.5**  
**CDMA 2.5**

**CDMD 0.3**  
**CDMD 0.5**  
**CDMD 0.7**  
**CDMD 1.0**  
**CDMD 1.5**  
**CDMD 2.5**

- characteristics according to EN 61984:

**4 poles 40A 400/690V 6kV 3**  
**2 poles 10A 250V 4kV 3**

- cULus (UL for USA and Canada),

certified

- rated voltage according to UL/CSA: 600V
- insulation resistance: ≥ 10 GΩ
- ambient temperature limit: -40 °C ... +125 °C
- made of self-extinguishing thermoplastic resin UL 94V-0
- mechanical life: ≥ 500 cycles
- contact resistance: ≤ 0,3 mΩ (4 poles), ≤ 3 mΩ (2 poles)
- for max. current load see the connector inserts derating diagram below; for more information see page 28

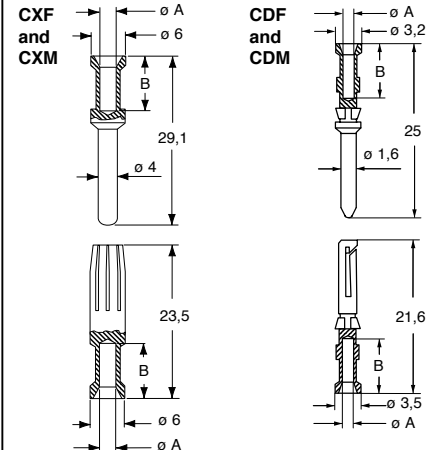
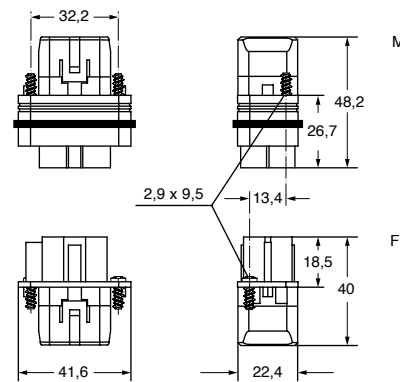

**CQ 04/2 power poles connector inserts**  
**Maximum current load derating diagram**

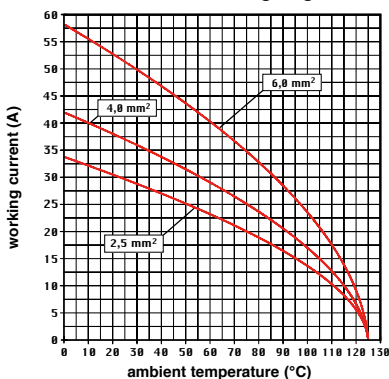

contacts side (front view)

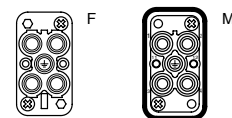

- each insert supplied with 2 fixing screws, self-tapping, zinc plated steel Ø2,9x9,5 mm, Ph1
- **it is recommended to crimp the contacts with crimping tools homologated by ILME** (please see the crimping tool section 40A contacts, CXF, CXM series and 10A contacts CDF, CDM series on pages 708 - 741)

**CXF and CXM contacts**

conductor section mm <sup>2</sup>	conductor slot ø A (mm)	conductors stripping length B (mm)
1,5	1,8	9
2,5	2,2	9
4	2,85	9,6
6	3,5	9,6

**CDF and CDM contacts**

conductor section mm <sup>2</sup>	conductor slot ø A (mm)	conductors stripping length B (mm)
0,14-0,37	0,9	8
0,5	1,1	8
0,75	1,3	8
1,0	1,45	8
1,5	1,8	8
2,5	2,2	6

Inserts

**CQ 8 poles + ⊕ 16A - 500V**

enclosures:  
size "32.13"

page:

insulating type  
EMC

365 - 367  
573 - 574

- can also be used partially fitted with 4 mm<sup>2</sup> section contacts

ISO 23570-3 standard and  
DESINA specification  
compliant



inserts, crimp connections



16A crimp contacts  
standard or for advanced opening  
silver and gold plated

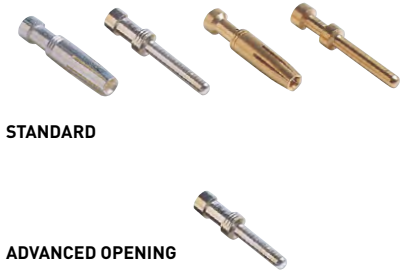

STANDARD

ADVANCED OPENING

description

part No.

part No.

without contacts (to be ordered separately)  
female inserts for female contacts  
male inserts for male contacts

**CQF 08**  
**CQM 08**

16A female contacts

0,14-0,37 mm <sup>2</sup>	AWG 26-22	one groove
0,5 mm <sup>2</sup>	AWG 20	with no grooves
0,75 mm <sup>2</sup>	AWG 18	one groove (back side)
1 mm <sup>2</sup>	AWG 18	one groove
1,5 mm <sup>2</sup>	AWG 16	two grooves
2,5 mm <sup>2</sup>	AWG 14	three grooves
3 mm <sup>2</sup>	AWG 12	one wide groove
4 mm <sup>2</sup>	AWG 12	with no grooves

16A male contacts

0,14-0,37 mm <sup>2</sup>	AWG 26-22	one groove
0,5 mm <sup>2</sup>	AWG 20	with no grooves
0,75 mm <sup>2</sup>	AWG 18	one groove (back side)
1 mm <sup>2</sup>	AWG 18	one groove
1,5 mm <sup>2</sup>	AWG 16	two grooves
2,5 mm <sup>2</sup>	AWG 14	three grooves
3 mm <sup>2</sup>	AWG 12	one wide groove
4 mm <sup>2</sup>	AWG 12	with no grooves

16A male crimp contacts for advanced opening

0,5 mm <sup>2</sup>	AWG 20	with no grooves
0,75 mm <sup>2</sup>	AWG 18	one groove (back side)
1 mm <sup>2</sup>	AWG 18	one groove
1,5 mm <sup>2</sup>	AWG 16	two grooves
2,5 mm <sup>2</sup>	AWG 14	three grooves

CCFA 0.3  
CCFA 0.5  
CCFA 0.7  
CCFA 1.0  
CCFA 1.5  
CCFA 2.5  
CCFA 3.0  
CCFA 4.0

silver plated

CCFD 0.3  
CCFD 0.5  
CCFD 0.7  
CCFD 1.0  
CCFD 1.5  
CCFD 2.5  
CCFD 3.0  
CCFD 4.0

gold plated\*

CCMA 0.3  
CCMA 0.5  
CCMA 0.7  
CCMA 1.0  
CCMA 1.5  
CCMA 2.5  
CCMA 3.0  
CCMA 4.0

CCMD 0.3  
CCMD 0.5  
CCMD 0.7  
CCMD 1.0  
CCMD 1.5  
CCMD 2.5  
CCMD 3.0  
CCMD 4.0

CC 0.5 AN  
CC 0.7 AN  
CC 1.0 AN  
CC 1.5 AN  
CC 2.5 AN

\* for basic or high thickness gold plating, please refer to page 675

- characteristics according to EN 61984:

**16A 500V 6kV 3**  
**16A 400/690V 8kV 2**

- certified

- rated voltage according to UL/CSA: 600V
- insulation resistance: ≥ 10 GΩ
- ambient temperature limit: -40 °C ... +125 °C
- made of self-extinguishing thermoplastic resin UL 94V-0
- mechanical life: ≥ 500 cycles
- contact resistance: ≤ 3 mΩ
- for max. current load see the connector inserts derating diagram below; for more information see page 28

**CQ 08 poles connector inserts**  
**Maximum current load derating diagram**

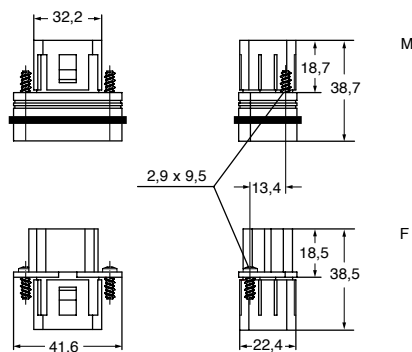
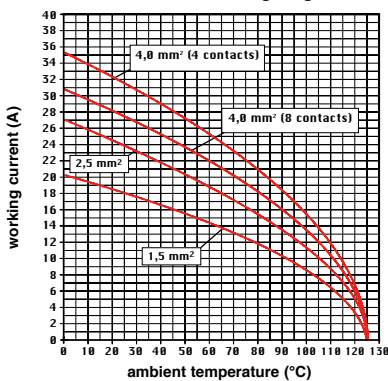

contacts side (front view)

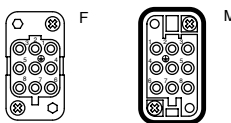

- each insert supplied with 2 fixing screws, self-tapping, zinc plated steel Ø2,9x9,5 mm, Ph1
- **it is recommended to crimp the contacts with crimping tools homologated by ILME** (please see the crimping tool section 16A contacts, CCF, CCM and CC...AN series on pages 708 - 741)

CCF and CCM

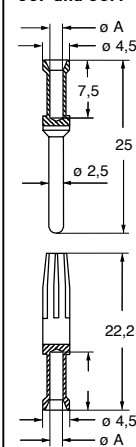

CC...AN

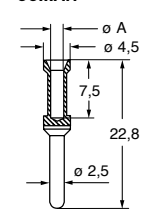

CCF, CCM and CC...AN contacts

conductor section mm <sup>2</sup>	conductor slot ø A (mm)	conductors stripping length (mm)
0,14-0,37	0,9	7,5
0,5	1,1	7,5
0,75	1,3	7,5
1,0	1,45	7,5
1,5	1,8	7,5
2,5	2,2	7,5
3	2,55	7,5
4	2,85	7,5

# CQ 17 poles + ⊕ 10A - 160V

enclosures:  
size "32.13"

page:

insulating type  
EMC

365 - 367  
573 - 574

## inserts, crimp connections

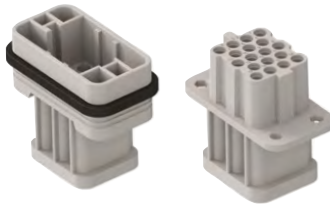

## 10A crimp contacts silver and gold plated



description	part No.	part No.
-------------	----------	----------

without contacts (to be ordered separately)  
female inserts for female contacts  
male inserts for male contacts

**CQF 17**  
**CQM 17**

### 10A female contacts

cross-section	AWG	identification No.
0,14-0,37 mm <sup>2</sup>	26-22	1
0,5 mm <sup>2</sup>	20	2
0,75 mm <sup>2</sup>	18	2
1 mm <sup>2</sup>	18	3
1,5 mm <sup>2</sup>	16	4
2,5 mm <sup>2</sup>	14	5

**CDFA 0.3**  
**CDFA 0.5**  
**CDFA 0.7**  
**CDFA 1.0**  
**CDFA 1.5**  
**CDFA 2.5**

silver plated

**CDFD 0.3**  
**CDFD 0.5**  
**CDFD 0.7**  
**CDFD 1.0**  
**CDFD 1.5**  
**CDFD 2.5**

gold plated+

### 10A male contacts

cross-section	AWG	identification No.
0,14-0,37 mm <sup>2</sup>	26-22	1
0,5 mm <sup>2</sup>	20	2
0,75 mm <sup>2</sup>	18	2
1 mm <sup>2</sup>	18	3
1,5 mm <sup>2</sup>	16	4
2,5 mm <sup>2</sup>	14	5

**CDMA 0.3**  
**CDMA 0.5**  
**CDMA 0.7**  
**CDMA 1.0**  
**CDMA 1.5**  
**CDMA 2.5**

**CDMD 0.3**  
**CDMD 0.5**  
**CDMD 0.7**  
**CDMD 1.0**  
**CDMD 1.5**  
**CDMD 2.5**

- characteristics according to EN 61984:

**10A 160V 2,5kV 3**  
**10A 250V 4kV 2**

- (UL for USA and Canada),

**ERC** certified

- rated voltage according to UL/CSA: 250V
- insulation resistance:  $\geq 10 \text{ G}\Omega$
- ambient temperature limit:  $-40 \text{ }^\circ\text{C} \dots +125 \text{ }^\circ\text{C}$
- made of self-extinguishing thermoplastic resin UL 94V-0
- mechanical life:  $\geq 500$  cycles
- contact resistance:  $\leq 3 \text{ m}\Omega$
- seat of PE contact on female insert set forward to obtain pre-leading PE
- each insert supplied with 2 fixing screws, self-tapping, zinc plated steel  $\text{O}2,9 \times 9,5 \text{ mm}$ , Ph1
- **it is recommended to crimp the contacts with crimping tools homologated by ILME** (please see the crimping tool section 10A contacts, CDF and CDM series on pages 708 - 741)
- for max. current load see the connector inserts derating diagram below; for more information see page 28

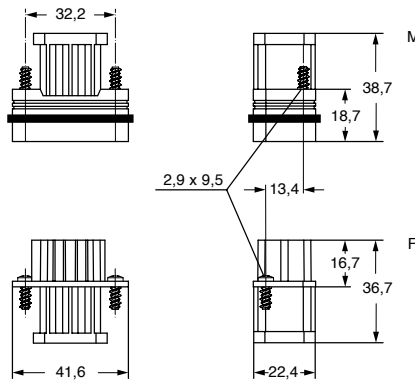

contacts side (front view)

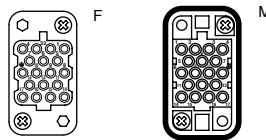

**CR CP coding pin**  
with loss of one contact  
(page 689)

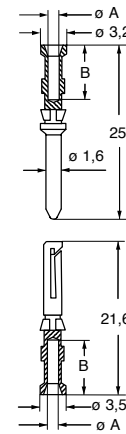

### CDF and CDM contacts

conductor section	conductor $\text{o A}$ (mm)	conductors stripping length B (mm)
0,14-0,37	0,9	8
0,5	1,1	8
0,75	1,3	8
1,0	1,45	8
1,5	1,8	8
2,5	2,2	6

† for basic or high thickness gold plating, please refer to page 674

**CQ 17 poles connector inserts**  
Maximum current load derating diagram

