

CM SH-SQUICH® 3 + 2 (aux) poles + ⊕ 16A - 830V

enclosures: size "57.27"	page:
C-TYPE IP65/IP66	393 - 401
C7 IP67, two levers	438
V-TYPE IP65/IP66, single lever	448 - 453
BIG hoods	468 - 469
T-TYPE IP65 insulating	482 - 483
T-TYPE / W IP66/IP69 insulating	490
HYGIENIC T-TYPE / H IP66/IP69	502
HYGIENIC T-TYPE / C IP66/IP69, -50 °C	507
W-TYPE for aggressive environments	522
E-Xtreme® corrosion proof	532 - 533, 543, 552 - 553
EMC	579
Central lever	606 - 608
LS-TYPE	620 - 621
IP68	636 - 639
panel supports:	page:
COB	652 - 653

inserts,
spring terminal connection without tools

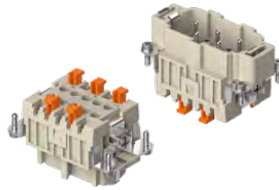

Q SILVER PLATED CONTACTS

description	part No.
-------------	----------

spring terminals with actuator button
female inserts with female contacts
male inserts with male contacts

CMSHF 03
CMSHM 03

- characteristics according to EN 61984:
16A 830V 8kV 3
16A 1000V 8kV 2
16A 720/1250V 8kV 2
- auxiliary contacts: **16A 500V 6kV 3**
- cULus (UL for USA and Canada), **ERC** certified
- rated voltage according to UL/CSA: 600V
- insulation resistance: ≥ 10 GΩ
- ambient temperature limit: -40 °C ... +125 °C
- made of self-extinguishing thermoplastic resin UL 94V-0
- mechanical life: ≥ 500 cycles
- contact resistance: ≤ 3 mΩ
- for max. current load see the connector inserts derating diagram below; for more information see page 28

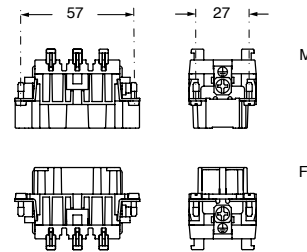

contacts side (front view)

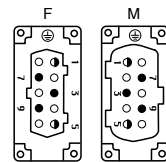

❶ the auxiliary contacts are in the forward position upon opening

- inserts for section conductors:
0,14 - 2,5 mm² - AWG 26 - 14
- conductors stripping length: 9...11 mm

CM SH 03 poles connector inserts
Maximum current load derating diagram

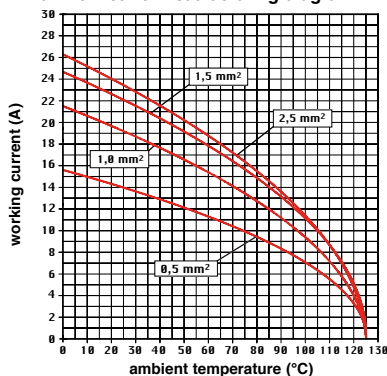

SQUICH®-spring connection technology

WIRING

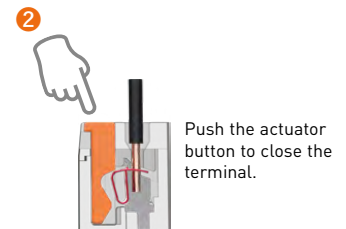
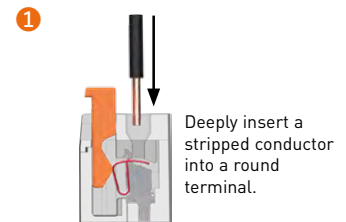

RE-OPENING

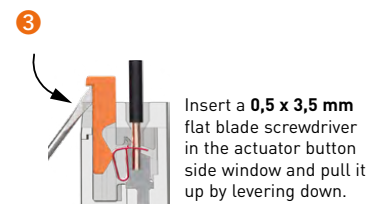

CM SH-SQUICH® 830V

CMCE 3 + 2 (aux) poles + ⊕ 16A - 830V

enclosures: size "57.27"	page:
C-TYPE IP65/IP66	393 - 401
C7 IP67, two levers	438
V-TYPE IP65/IP66, single lever	448 - 453
BIG hoods	468 - 469
T-TYPE IP65 insulating	482 - 483
T-TYPE / W IP66/IP69 insulating	490
HYGIENIC T-TYPE / H IP66/IP69	502
HYGIENIC T-TYPE / C IP66/IP69, -50 °C	507
W-TYPE for aggressive environments	522
E-Xtreme® corrosion proof	532 - 533, 543, 552 - 553
EMC	579
Central lever	606 - 608
LS-TYPE	620 - 621
IP68	636 - 639
panel supports: COB	page: 652 - 653

inserts, crimp connections

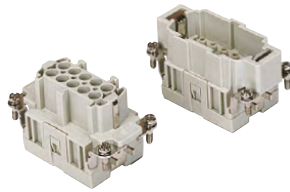

16A crimp contacts
standard or for advanced opening
silver and gold plated

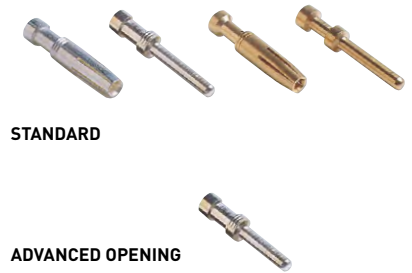

description	part No.	part No.
-------------	----------	----------

without contacts (to be ordered separately)
female inserts for female contacts **CMCEF 03**
male inserts for male contacts **CMCEM 03**

<p>16A female contacts</p> <table border="0"> <tr><td>0,14-0,37 mm²</td><td>AWG 26-22</td><td>one groove</td></tr> <tr><td>0,5 mm²</td><td>AWG 20</td><td>with no grooves</td></tr> <tr><td>0,75 mm²</td><td>AWG 18</td><td>one groove (back side)</td></tr> <tr><td>1 mm²</td><td>AWG 18</td><td>one groove</td></tr> <tr><td>1,5 mm²</td><td>AWG 16</td><td>two grooves</td></tr> <tr><td>2,5 mm²</td><td>AWG 14</td><td>three grooves</td></tr> <tr><td>3 mm²</td><td>AWG 12</td><td>one wide groove</td></tr> <tr><td>4 mm²</td><td>AWG 12</td><td>with no grooves</td></tr> </table> <p>16A male contacts</p> <table border="0"> <tr><td>0,14-0,37 mm²</td><td>AWG 26-22</td><td>one groove</td></tr> <tr><td>0,5 mm²</td><td>AWG 20</td><td>with no grooves</td></tr> <tr><td>0,75 mm²</td><td>AWG 18</td><td>one groove (back side)</td></tr> <tr><td>1 mm²</td><td>AWG 18</td><td>one groove</td></tr> <tr><td>1,5 mm²</td><td>AWG 16</td><td>two grooves</td></tr> <tr><td>2,5 mm²</td><td>AWG 14</td><td>three grooves</td></tr> <tr><td>3 mm²</td><td>AWG 12</td><td>one wide groove</td></tr> <tr><td>4 mm²</td><td>AWG 12</td><td>with no grooves</td></tr> </table> <p>16A male crimp contacts for advanced opening</p> <table border="0"> <tr><td>0,5 mm²</td><td>AWG 20</td><td>with no grooves</td></tr> <tr><td>0,75 mm²</td><td>AWG 18</td><td>one groove (back side)</td></tr> <tr><td>1 mm²</td><td>AWG 18</td><td>one groove</td></tr> <tr><td>1,5 mm²</td><td>AWG 16</td><td>two grooves</td></tr> <tr><td>2,5 mm²</td><td>AWG 14</td><td>three grooves</td></tr> </table>	0,14-0,37 mm ²	AWG 26-22	one groove	0,5 mm ²	AWG 20	with no grooves	0,75 mm ²	AWG 18	one groove (back side)	1 mm ²	AWG 18	one groove	1,5 mm ²	AWG 16	two grooves	2,5 mm ²	AWG 14	three grooves	3 mm ²	AWG 12	one wide groove	4 mm ²	AWG 12	with no grooves	0,14-0,37 mm ²	AWG 26-22	one groove	0,5 mm ²	AWG 20	with no grooves	0,75 mm ²	AWG 18	one groove (back side)	1 mm ²	AWG 18	one groove	1,5 mm ²	AWG 16	two grooves	2,5 mm ²	AWG 14	three grooves	3 mm ²	AWG 12	one wide groove	4 mm ²	AWG 12	with no grooves	0,5 mm ²	AWG 20	with no grooves	0,75 mm ²	AWG 18	one groove (back side)	1 mm ²	AWG 18	one groove	1,5 mm ²	AWG 16	two grooves	2,5 mm ²	AWG 14	three grooves	<p>silver plated</p>	<p>gold plated+</p>
0,14-0,37 mm ²	AWG 26-22	one groove																																																															
0,5 mm ²	AWG 20	with no grooves																																																															
0,75 mm ²	AWG 18	one groove (back side)																																																															
1 mm ²	AWG 18	one groove																																																															
1,5 mm ²	AWG 16	two grooves																																																															
2,5 mm ²	AWG 14	three grooves																																																															
3 mm ²	AWG 12	one wide groove																																																															
4 mm ²	AWG 12	with no grooves																																																															
0,14-0,37 mm ²	AWG 26-22	one groove																																																															
0,5 mm ²	AWG 20	with no grooves																																																															
0,75 mm ²	AWG 18	one groove (back side)																																																															
1 mm ²	AWG 18	one groove																																																															
1,5 mm ²	AWG 16	two grooves																																																															
2,5 mm ²	AWG 14	three grooves																																																															
3 mm ²	AWG 12	one wide groove																																																															
4 mm ²	AWG 12	with no grooves																																																															
0,5 mm ²	AWG 20	with no grooves																																																															
0,75 mm ²	AWG 18	one groove (back side)																																																															
1 mm ²	AWG 18	one groove																																																															
1,5 mm ²	AWG 16	two grooves																																																															
2,5 mm ²	AWG 14	three grooves																																																															
<table border="0"> <tr><td>CCFA 0.3</td><td>CCFD 0.3</td></tr> <tr><td>CCFA 0.5</td><td>CCFD 0.5</td></tr> <tr><td>CCFA 0.7</td><td>CCFD 0.7</td></tr> <tr><td>CCFA 1.0</td><td>CCFD 1.0</td></tr> <tr><td>CCFA 1.5</td><td>CCFD 1.5</td></tr> <tr><td>CCFA 2.5</td><td>CCFD 2.5</td></tr> <tr><td>CCFA 3.0</td><td>CCFD 3.0</td></tr> <tr><td>CCFA 4.0</td><td>CCFD 4.0</td></tr> </table> <table border="0"> <tr><td>CCMA 0.3</td><td>CCMD 0.3</td></tr> <tr><td>CCMA 0.5</td><td>CCMD 0.5</td></tr> <tr><td>CCMA 0.7</td><td>CCMD 0.7</td></tr> <tr><td>CCMA 1.0</td><td>CCMD 1.0</td></tr> <tr><td>CCMA 1.5</td><td>CCMD 1.5</td></tr> <tr><td>CCMA 2.5</td><td>CCMD 2.5</td></tr> <tr><td>CCMA 3.0</td><td>CCMD 3.0</td></tr> <tr><td>CCMA 4.0</td><td>CCMD 4.0</td></tr> </table> <table border="0"> <tr><td>CC 0.5 AN</td><td rowspan="4">* for basic or high thickness gold plating, please refer to page 675</td></tr> <tr><td>CC 0.7 AN</td></tr> <tr><td>CC 1.0 AN</td></tr> <tr><td>CC 1.5 AN</td></tr> <tr><td>CC 2.5 AN</td><td></td></tr> </table>	CCFA 0.3	CCFD 0.3	CCFA 0.5	CCFD 0.5	CCFA 0.7	CCFD 0.7	CCFA 1.0	CCFD 1.0	CCFA 1.5	CCFD 1.5	CCFA 2.5	CCFD 2.5	CCFA 3.0	CCFD 3.0	CCFA 4.0	CCFD 4.0	CCMA 0.3	CCMD 0.3	CCMA 0.5	CCMD 0.5	CCMA 0.7	CCMD 0.7	CCMA 1.0	CCMD 1.0	CCMA 1.5	CCMD 1.5	CCMA 2.5	CCMD 2.5	CCMA 3.0	CCMD 3.0	CCMA 4.0	CCMD 4.0	CC 0.5 AN	* for basic or high thickness gold plating, please refer to page 675	CC 0.7 AN	CC 1.0 AN	CC 1.5 AN	CC 2.5 AN																											
CCFA 0.3	CCFD 0.3																																																																
CCFA 0.5	CCFD 0.5																																																																
CCFA 0.7	CCFD 0.7																																																																
CCFA 1.0	CCFD 1.0																																																																
CCFA 1.5	CCFD 1.5																																																																
CCFA 2.5	CCFD 2.5																																																																
CCFA 3.0	CCFD 3.0																																																																
CCFA 4.0	CCFD 4.0																																																																
CCMA 0.3	CCMD 0.3																																																																
CCMA 0.5	CCMD 0.5																																																																
CCMA 0.7	CCMD 0.7																																																																
CCMA 1.0	CCMD 1.0																																																																
CCMA 1.5	CCMD 1.5																																																																
CCMA 2.5	CCMD 2.5																																																																
CCMA 3.0	CCMD 3.0																																																																
CCMA 4.0	CCMD 4.0																																																																
CC 0.5 AN	* for basic or high thickness gold plating, please refer to page 675																																																																
CC 0.7 AN																																																																	
CC 1.0 AN																																																																	
CC 1.5 AN																																																																	
CC 2.5 AN																																																																	

- characteristics according to EN 61984:
- 16A 830V 8kV 3**
- 16A 1000V 8kV 2**
- 16A 720/1250V 8kV 2**
- auxiliary contacts: **16A 500V 6kV 3**
- certified
- rated voltage according to UL/CSA: 600V
- insulation resistance: ≥ 10 GΩ
- ambient temperature limit: -40 °C ... +125 °C
- made of self-extinguishing thermoplastic resin UL 94V-0
- mechanical life: ≥ 500 cycles
- contact resistance: ≤ 1 mΩ
- for max. current load see the connector inserts derating diagram below; for more information see page 28

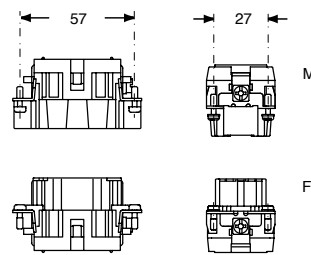

contacts side (front view)

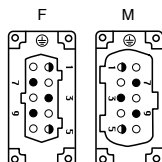

the auxiliary contacts are in the forward position upon opening

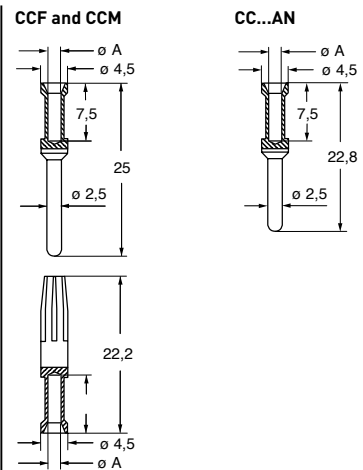

CCF, CCM and CC...AN contacts

conductor section mm ²	conductor slot ø A (mm)	conductors stripping length (mm)
0,14-0,37	0,9	7,5
0,5	1,1	7,5
0,75	1,3	7,5
1,0	1,45	7,5
1,5	1,8	7,5
2,5	2,2	7,5
3	2,55	7,5
4	2,85	7,5

CMCE 03 poles connector inserts
Maximum current load derating diagram

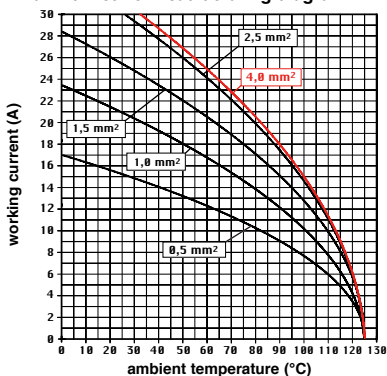

- it is recommended to crimp the contacts with crimping tools homologated by ILME (please see the crimping tool section 16A contacts, CCF, CCM and CC...AN series on pages 708 - 741)

CMSH-SQUICH® 6 + 2 (aux) poles + ⊕ 16A - 830V

enclosures: size "77.27"	page:
C-TYPE IP65/IP66	402 - 411
C7 IP67, two levers	439 - 440
V-TYPE IP65/IP66, single lever	454 - 458
BIG hoods	470 - 471
T-TYPE IP65 insulating	484 - 485
T-TYPE / W IP66/IP69 insulating	491
HYGIENIC T-TYPE / H IP66/IP69	503
HYGIENIC T-TYPE / C IP66/IP69, -50 °C	508
W-TYPE for aggressive environments	523
E-Xtreme® corrosion proof	534 - 535, 544, 554 - 555
EMC	580
Central lever	609 - 611
LS-TYPE	622 - 623
IP68	640 - 643
panel supports:	page:
COB	652 - 653

inserts,
spring terminal connection without tools

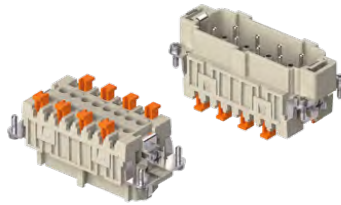

Q SILVER PLATED CONTACTS

description

part No.



spring terminals with actuator button
female inserts with female contacts
male inserts with male contacts

CMSHF 06
CMSHM 06

- characteristics according to EN 61984:

16A 830V 8kV 3
16A 1000V 8kV 2
16A 720/1250V 8kV 2

- auxiliary contacts: **16A 500V 6kV 3**

- cULus (UL for USA and Canada),  
ERC certified

- rated voltage according to UL/CSA: 600V
- insulation resistance: $\geq 10 \text{ G}\Omega$
- ambient temperature limit: -40 °C ... +125 °C
- made of self-extinguishing thermoplastic resin
UL 94V-0

- mechanical life: ≥ 500 cycles
- contact resistance: $\leq 3 \text{ m}\Omega$
- for max. current load see the connector inserts derating diagram below; for more information see page 28

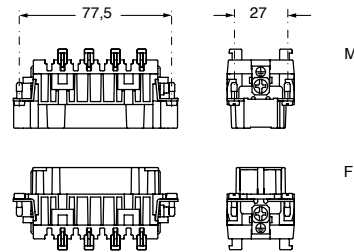

contacts side (front view)

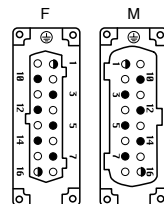

● the auxiliary contacts are in the forward position upon opening

- inserts for section conductors:
0,14 - 2,5 mm² - AWG 26 - 14
- conductors stripping length: 9...11 mm

CMSH 06 poles connector inserts
Maximum current load derating diagram

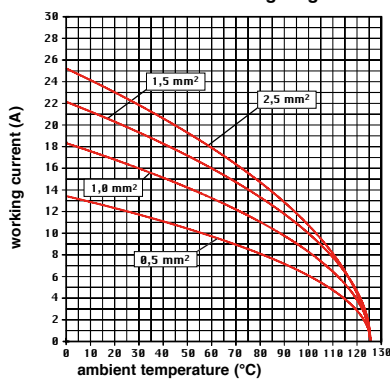

SQUICH®-spring connection technology

WIRING

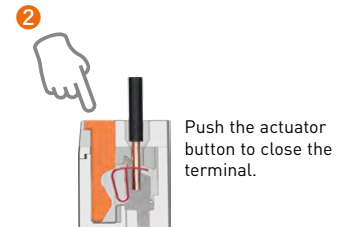
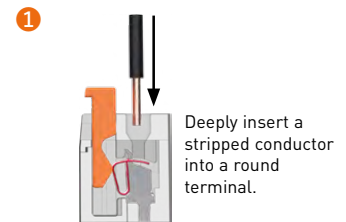

RE-OPENING

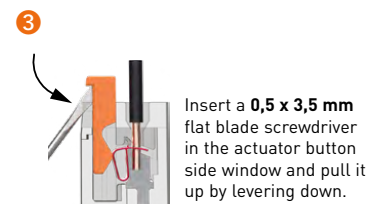

CMCE 6 + 2 (aux) poles + ⊕ 16A - 830V

enclosures: size "77.27"	page:
C-TYPE IP65/IP66	402 - 411
C7 IP67, two levers	439 - 440
V-TYPE IP65/IP66, single lever	454 - 458
BIG hoods	470 - 471
T-TYPE IP65 insulating	484 - 485
T-TYPE / W IP66/IP69 insulating	491
HYGIENIC T-TYPE / H IP66/IP69	503
HYGIENIC T-TYPE / C IP66/IP69, -50 °C	508
W-TYPE for aggressive environments	523
E-Xtreme® corrosion proof	534 - 535, 544, 554 - 555
EMC	580
Central lever	609 - 611
LS-TYPE	622 - 623
IP68	640 - 643
panel supports: COB	page: 652 - 653

inserts, crimp connections

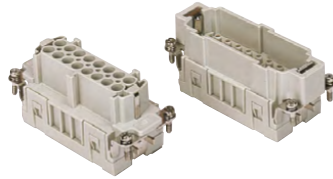

16A crimp contacts
standard or for advanced opening
silver and gold plated

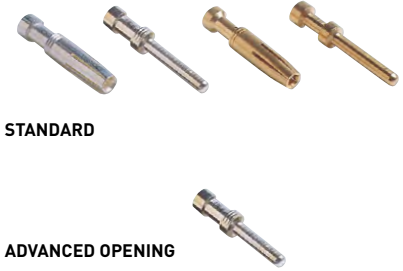

STANDARD

ADVANCED OPENING

description	part No.	part No.
-------------	----------	----------

without contacts (to be ordered separately)
female inserts for female contacts **CMCEF 06**
male inserts for male contacts **CMCEM 06**

16A female contacts

0,14-0,37 mm ²	AWG 26-22	one groove
0,5 mm ²	AWG 20	with no grooves
0,75 mm ²	AWG 18	one groove (back side)
1 mm ²	AWG 18	one groove
1,5 mm ²	AWG 16	two grooves
2,5 mm ²	AWG 14	three grooves
3 mm ²	AWG 12	one wide groove
4 mm ²	AWG 12	with no grooves

16A male contacts

0,14-0,37 mm ²	AWG 26-22	one groove
0,5 mm ²	AWG 20	with no grooves
0,75 mm ²	AWG 18	one groove (back side)
1 mm ²	AWG 18	one groove
1,5 mm ²	AWG 16	two grooves
2,5 mm ²	AWG 14	three grooves
3 mm ²	AWG 12	one wide groove
4 mm ²	AWG 12	with no grooves

16A male crimp contacts for advanced opening

0,5 mm ²	AWG 20	with no grooves
0,75 mm ²	AWG 18	one groove (back side)
1 mm ²	AWG 18	one groove
1,5 mm ²	AWG 16	two grooves
2,5 mm ²	AWG 14	three grooves

CCFA 0.3	CCFD 0.3
CCFA 0.5	CCFD 0.5
CCFA 0.7	CCFD 0.7
CCFA 1.0	CCFD 1.0
CCFA 1.5	CCFD 1.5
CCFA 2.5	CCFD 2.5
CCFA 3.0	CCFD 3.0
CCFA 4.0	CCFD 4.0

CCMA 0.3	CCMD 0.3
CCMA 0.5	CCMD 0.5
CCMA 0.7	CCMD 0.7
CCMA 1.0	CCMD 1.0
CCMA 1.5	CCMD 1.5
CCMA 2.5	CCMD 2.5
CCMA 3.0	CCMD 3.0
CCMA 4.0	CCMD 4.0

CC 0.5 AN
CC 0.7 AN
CC 1.0 AN
CC 1.5 AN
CC 2.5 AN

* for basic or high thickness gold plating, please refer to page 675

- characteristics according to EN 61984:
16A 830V 8kV 3
16A 1000V 8kV 2
16A 720/1250V 8kV 2
- auxiliary contacts: **16A 500V 6kV 3**
- certified
- rated voltage according to UL/CSA: 600V
- insulation resistance: ≥ 10 GΩ
- ambient temperature limit: -40 °C ... +125 °C
- made of self-extinguishing thermoplastic resin UL 94V-0
- mechanical life: ≥ 500 cycles
- contact resistance: ≤ 1 mΩ
- for max. current load see the connector inserts derating diagram below; for more information see page 28

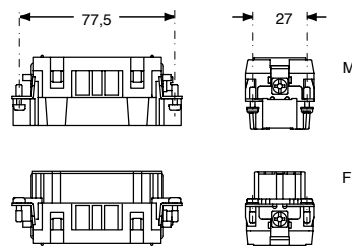

contacts side (front view)

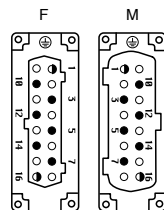

the auxiliary contacts are in the forward position upon opening

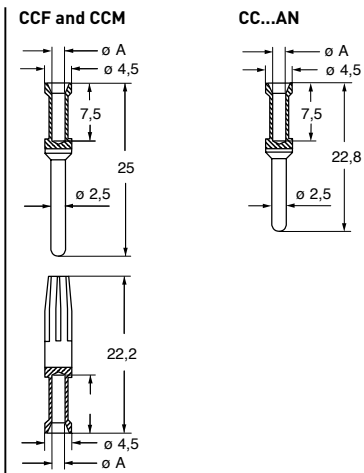

CCF, CCM and CC...AN contacts

conductor section mm ²	conductor slot ø A (mm)	conductors stripping length (mm)
0,14-0,37	0,9	7,5
0,5	1,1	7,5
0,75	1,3	7,5
1,0	1,45	7,5
1,5	1,8	7,5
2,5	2,2	7,5
3	2,55	7,5
4	2,85	7,5

CMCE 06 poles connector inserts
Maximum current load derating diagram

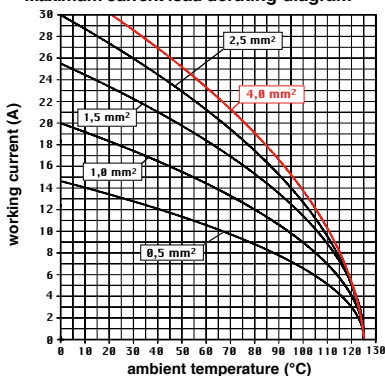

- it is recommended to crimp the contacts with crimping tools homologated by ILME (please see the crimping tool section 16A contacts, CCF, CCM and CC...AN series on pages 708 - 741)

CM SH-SQUICH® 10 + 2 (aux) poles + ⊕ 16A - 830V

enclosures: size "104.27"	page:
C-TYPE IP65/IP66	412 - 423
C7 IP67, two levers	441 - 442
V-TYPE IP65/IP66, single lever	459 - 463
BIG hoods	472 - 473
T-TYPE IP65 insulating	486 - 487
T-TYPE / W IP66/IP69 insulating	492
HYGIENIC T-TYPE / H IP66/IP69	504
HYGIENIC T-TYPE / C IP66/IP69, -50 °C	509
W-TYPE for aggressive environments	524
E-Xtreme® corrosion proof	536 - 537, 545, 556 - 557
EMC	581
Central lever	612 - 614
LS-TYPE	624 - 625
IP68	644 - 647
panel supports:	page:
COB	652 - 653

inserts,
spring terminal connection without tools

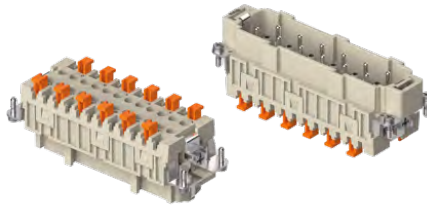

Q SILVER PLATED CONTACTS

description	part No.
spring terminals with actuator button	CMSHF 10
female inserts with female contacts	CMSHM 10
male inserts with male contacts	

- characteristics according to EN 61984:
16A 830V 8kV 3
16A 1000V 8kV 2
16A 720/1250V 8kV 2
- auxiliary contacts: **16A 500V 6kV 3**
- cULus (UL for USA and Canada), DNV-GL, BUREAU VERITAS, EAC certified
- rated voltage according to UL/CSA: 600V
- insulation resistance: $\geq 10 \text{ G}\Omega$
- ambient temperature limit: -40 °C ... +125 °C
- made of self-extinguishing thermoplastic resin UL 94V-0
- mechanical life: ≥ 500 cycles
- contact resistance: $\leq 3 \text{ m}\Omega$
- for max. current load see the connector inserts derating diagram below; for more information see page 28

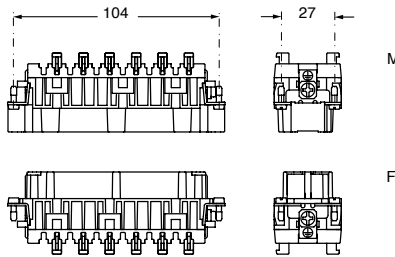

contacts side (front view)

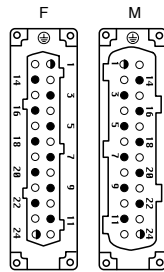

the auxiliary contacts are in the forward position upon opening

- inserts for section conductors: 0,14 - 2,5 mm² - AWG 26 - 14
- conductors stripping length: 9...11 mm

CMSH 10 poles connector inserts
Maximum current load derating diagram

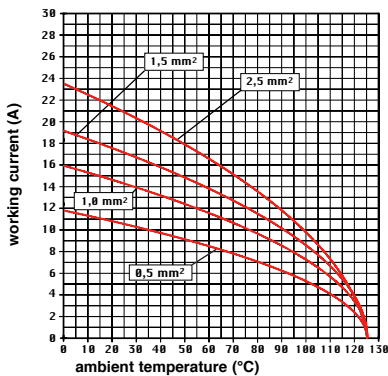

SQUICH®-spring connection technology

WIRING

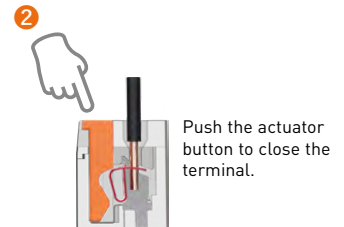
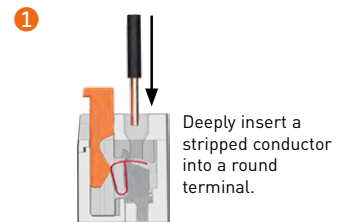

RE-OPENING

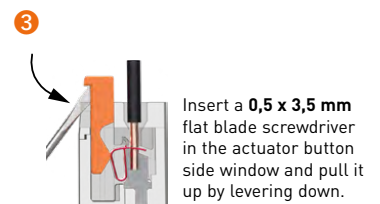

CM SH-SQUICH® 830V

CMCE 10 + 2 (aux) poles + ⊕ 16A - 830V

enclosures: size "104.27"	page:
C-TYPE IP65/IP66	412 - 423
C7 IP67, two levers	441 - 442
V-TYPE IP65/IP66, single lever	459 - 463
BIG hoods	472 - 473
T-TYPE IP65 insulating	486 - 487
T-TYPE / W IP66/IP69 insulating	492
HYGIENIC T-TYPE / H IP66/IP69	504
HYGIENIC T-TYPE / C IP66/IP69, -50 °C	509
W-TYPE for aggressive environments	524
E-Xtreme® corrosion proof	536 - 537, 545, 556 - 557
EMC	581
Central lever	612 - 614
LS-TYPE	624 - 625
IP68	644 - 647
panel supports: COB	page: 652 - 653

inserts, crimp connections

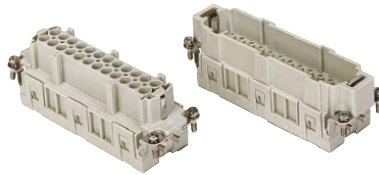

16A crimp contacts
standard or for advanced opening
silver and gold plated

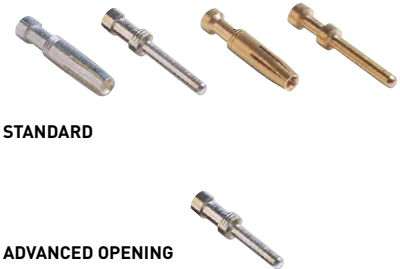

description	part No.	part No.
-------------	----------	----------

without contacts (to be ordered separately)
female inserts for female contacts
male inserts for male contacts

CMCEF 10
CMCEM 10

16A female contacts

0,14-0,37 mm ²	AWG 26-22	one groove
0,5 mm ²	AWG 20	with no grooves
0,75 mm ²	AWG 18	one groove (back side)
1 mm ²	AWG 18	one groove
1,5 mm ²	AWG 16	two grooves
2,5 mm ²	AWG 14	three grooves
3 mm ²	AWG 12	one wide groove
4 mm ²	AWG 12	with no grooves

16A male contacts

0,14-0,37 mm ²	AWG 26-22	one groove
0,5 mm ²	AWG 20	with no grooves
0,75 mm ²	AWG 18	one groove (back side)
1 mm ²	AWG 18	one groove
1,5 mm ²	AWG 16	two grooves
2,5 mm ²	AWG 14	three grooves
3 mm ²	AWG 12	one wide groove
4 mm ²	AWG 12	with no grooves

16A male crimp contacts for advanced opening

0,5 mm ²	AWG 20	with no grooves
0,75 mm ²	AWG 18	one groove (back side)
1 mm ²	AWG 18	one groove
1,5 mm ²	AWG 16	two grooves
2,5 mm ²	AWG 14	three grooves

CCFA 0.3	CCFD 0.3
CCFA 0.5	CCFD 0.5
CCFA 0.7	CCFD 0.7
CCFA 1.0	CCFD 1.0
CCFA 1.5	CCFD 1.5
CCFA 2.5	CCFD 2.5
CCFA 3.0	CCFD 3.0
CCFA 4.0	CCFD 4.0

CCMA 0.3	CCMD 0.3
CCMA 0.5	CCMD 0.5
CCMA 0.7	CCMD 0.7
CCMA 1.0	CCMD 1.0
CCMA 1.5	CCMD 1.5
CCMA 2.5	CCMD 2.5
CCMA 3.0	CCMD 3.0
CCMA 4.0	CCMD 4.0

CC 0.5 AN
CC 0.7 AN
CC 1.0 AN
CC 1.5 AN
CC 2.5 AN

+ for basic or high thickness gold plating, please refer to page 675

- characteristics according to EN 61984:

16A 830V 8kV 3
16A 1000V 8kV 2
16A 720/1250V 8kV 2
- auxiliary contacts: **16A 500V 6kV 3**

- certified

- rated voltage according to UL/CSA: 600V
- insulation resistance: ≥ 10 GΩ
- ambient temperature limit: -40 °C ... +125 °C
- made of self-extinguishing thermoplastic resin UL 94V-0
- mechanical life: ≥ 500 cycles
- contact resistance: ≤ 1 mΩ
- for max. current load see the connector inserts derating diagram below; for more information see page 28

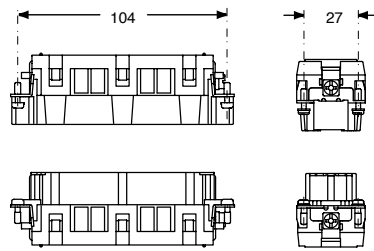

contacts side (front view)

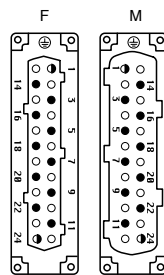

the auxiliary contacts are in the forward position upon opening

CCF and CCM

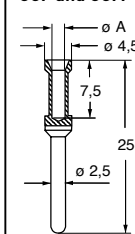

CC...AN

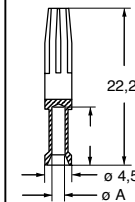
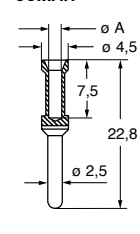

CCF, CCM and CC...AN contacts

conductor section mm ²	conductor slot ø A (mm)	conductors stripping length (mm)
0,14-0,37	0,9	7,5
0,5	1,1	7,5
0,75	1,3	7,5
1,0	1,45	7,5
1,5	1,8	7,5
2,5	2,2	7,5
3	2,55	7,5
4	2,85	7,5

CMCE 10 poles connector inserts
Maximum current load derating diagram

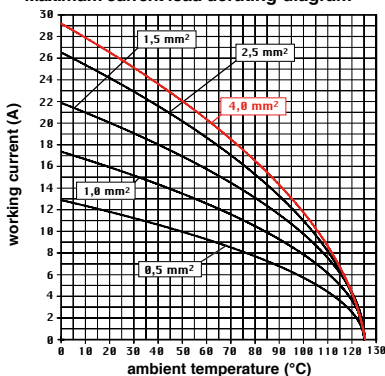

- it is recommended to crimp the contacts with crimping tools homologated by ILME (please see the crimping tool section 16A contacts, CCF, CCM and CC...AN series on pages 708 - 741)

CMSH-SQUICH® 12 + 4 (aux) poles + ⊕ 16A - 830V

enclosures:
size "77.62"

page:

C-TYPE IP65/IP66

424 - 429

W-TYPE for aggressive environments

525

E-Xtreme® corrosion proof

546

inserts,
spring terminal connection without tools

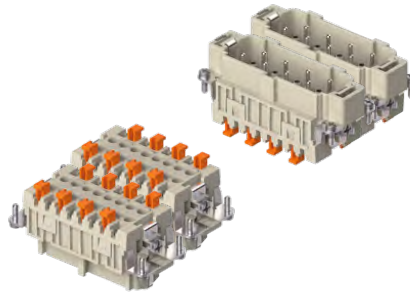

Q SILVER PLATED CONTACTS

description

part No.

part No.

spring terminals with actuator button
female inserts with female contacts, No. (1-16) and (17-32)
male inserts with male contacts, No. (1-16) and (17-32)

CMSHF 06
CMSHM 06

CMSHF 06 N
CMSHM 06 N

- characteristics according to EN 61984:

16A 830V 8kV 3

16A 1000V 8kV 2

16A 720/1250V 8kV 2

- auxiliary contacts: **16A 500V 6kV 3**

- cULus (UL for USA and Canada), DNV-GL, BUREAU VERITAS

ERC certified

- rated voltage according to UL/CSA: 600V

- insulation resistance: $\geq 10 \text{ G}\Omega$

- ambient temperature limit: $-40 \text{ }^\circ\text{C} \dots +125 \text{ }^\circ\text{C}$

- made of self-extinguishing thermoplastic resin
UL 94V-0

- mechanical life: ≥ 500 cycles

- contact resistance: $\leq 3 \text{ m}\Omega$

- for max. current load see the connector inserts
derating diagram below; for more information see
page 28

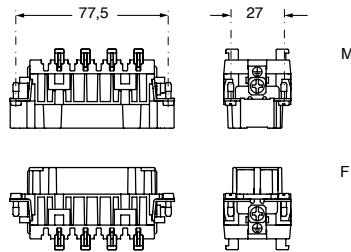

contacts side (front view)

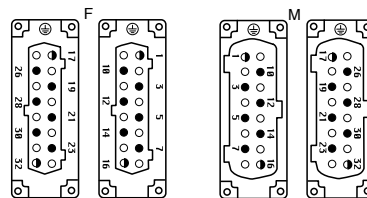

● the auxiliary contacts are in the forward position upon opening

- inserts for section conductors:

0,14 - 2,5 mm² - AWG 26 - 14

- conductors stripping length: 9...11 mm

SQUICH®-spring connection technology

WIRING

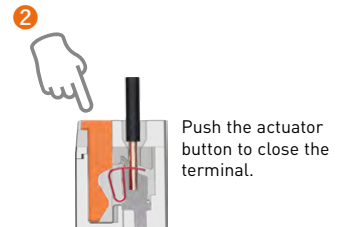
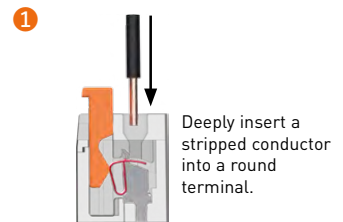

RE-OPENING

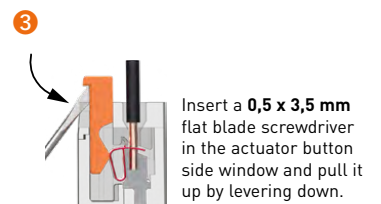

CMSH 12 poles connector inserts
Maximum current load derating diagram

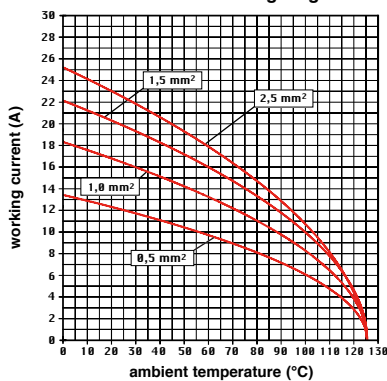

CMCE 12 + 4 (aux) poles + ⊕ 16A - 830V

enclosures:
size "77.62"

page:

C-TYPE IP65/IP66

424 - 429

W-TYPE for aggressive environments

525

E-Xtreme® corrosion proof

546

inserts, crimp connections

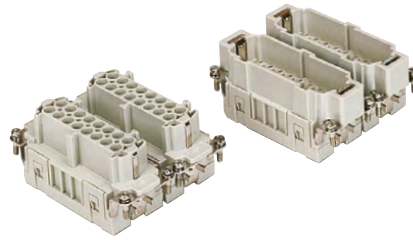

16A crimp contacts standard or for advanced opening silver and gold plated

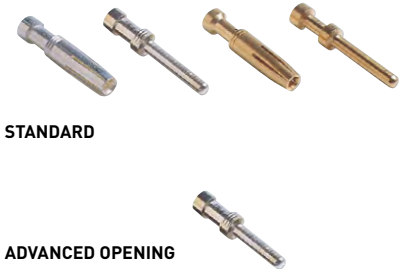

description	part No.	part No.	part No.
-------------	----------	----------	----------

without contacts (to be ordered separately)
female inserts for female contacts, No. (1-16) and (17-32)
male inserts for male contacts, No. (1-16) and (17-32)

CMCEF 06
CMCEM 06

CMCEF 06 N
CMCEM 06 N

16A female contacts

Area	AWG	Configuration
0,14-0,37 mm ²	AWG 26-22	one groove
0,5 mm ²	AWG 20	with no grooves
0,75 mm ²	AWG 18	one groove (back side)
1 mm ²	AWG 18	one groove
1,5 mm ²	AWG 16	two grooves
2,5 mm ²	AWG 14	three grooves
3 mm ²	AWG 12	one wide groove
4 mm ²	AWG 12	with no grooves

CCFA 0.3
CCFA 0.5
CCFA 0.7
CCFA 1.0
CCFA 1.5
CCFA 2.5
CCFA 3.0
CCFA 4.0

CCFD 0.3
CCFD 0.5
CCFD 0.7
CCFD 1.0
CCFD 1.5
CCFD 2.5
CCFD 3.0
CCFD 4.0

silver plated

gold plated+

16A male contacts

Area	AWG	Configuration
0,14-0,37 mm ²	AWG 26-22	one groove
0,5 mm ²	AWG 20	with no grooves
0,75 mm ²	AWG 18	one groove (back side)
1 mm ²	AWG 18	one groove
1,5 mm ²	AWG 16	two grooves
2,5 mm ²	AWG 14	three grooves
3 mm ²	AWG 12	one wide groove
4 mm ²	AWG 12	with no grooves

CCMA 0.3
CCMA 0.5
CCMA 0.7
CCMA 1.0
CCMA 1.5
CCMA 2.5
CCMA 3.0
CCMA 4.0

CCMD 0.3
CCMD 0.5
CCMD 0.7
CCMD 1.0
CCMD 1.5
CCMD 2.5
CCMD 3.0
CCMD 4.0

16A male crimp contacts for advanced opening

Area	AWG	Configuration
0,5 mm ²	AWG 20	with no grooves
0,75 mm ²	AWG 18	one groove (back side)
1 mm ²	AWG 18	one groove
1,5 mm ²	AWG 16	two grooves
2,5 mm ²	AWG 14	three grooves

CC 0.5 AN
CC 0.7 AN
CC 1.0 AN
CC 1.5 AN
CC 2.5 AN

* for basic or high thickness gold plating, please refer to page 675

- characteristics according to EN 61984:

- 16A 830V 8kV 3
- 16A 1000V 8kV 2
- 16A 720/1250V 8kV 2
- auxiliary contacts: 16A 500V 6kV 3

- certified

- rated voltage according to UL/CSA: 600V
- insulation resistance: ≥ 10 GΩ
- ambient temperature limit: -40 °C ... +125 °C
- made of self-extinguishing thermoplastic resin UL 94V-0
- mechanical life: ≥ 500 cycles
- contact resistance: ≤ 1 mΩ
- for max. current load see the connector inserts derating diagram below; for more information see page 28

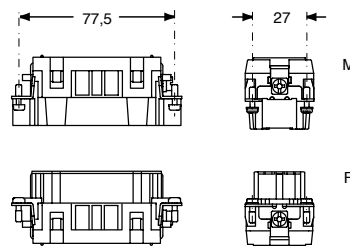

contacts side (front view)

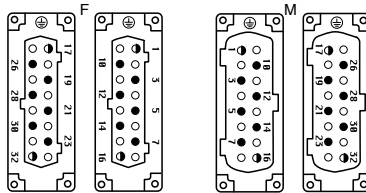

● the auxiliary contacts are in the forward position upon opening

CCF and CCM

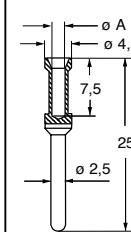

CC...AN

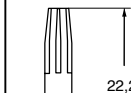
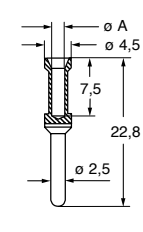

CCF, CCM and CC...AN contacts

conductor section mm ²	conductor slot ø A (mm)	conductors stripping length (mm)
0,14-0,37	0,9	7,5
0,5	1,1	7,5
0,75	1,3	7,5
1,0	1,45	7,5
1,5	1,8	7,5
2,5	2,2	7,5
3	2,55	7,5
4	2,85	7,5

CMCE 12 poles connector inserts
Maximum current load derating diagram

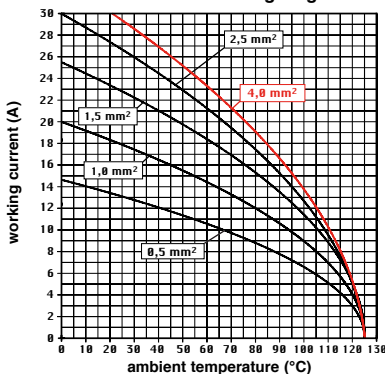

- it is recommended to crimp the contacts with crimping tools homologated by ILME (please see the crimping tool section 16A contacts, CCF, CCM and CC...AN series on pages 708 - 741)

Inserts

CMSH-SQUICH® 20 + 4 (aux) poles + ⊕ 16A - 830V

enclosures:
size "104.62"

page:

C-TYPE IP65/IP66
W-TYPE for aggressive environments
E-Xtreme® corrosion proof

430
526
547

inserts,
spring terminal connection without tools

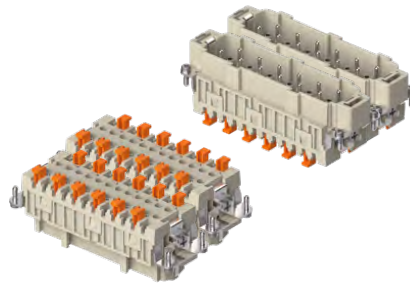

Q SILVER PLATED CONTACTS

description

part No.

part No.

spring terminals with actuator button
female inserts with female contacts, No. (1-24) and (25-48)
male inserts with male contacts, No. (1-24) and (25-48)

CMSHF 10
CMSHM 10

CMSHF 10 N
CMSHM 10 N

- characteristics according to EN 61984:
16A 830V 8kV 3
16A 1000V 8kV 2
16A 720/1250V 8kV 2

- auxiliary contacts: **16A 500V 6kV 3**

- cULus (UL for USA and Canada),

ERC certified

- rated voltage according to UL/CSA: 600V
- insulation resistance: $\geq 10 \text{ G}\Omega$
- ambient temperature limit: $-40 \text{ }^\circ\text{C} \dots +125 \text{ }^\circ\text{C}$
- made of self-extinguishing thermoplastic resin UL 94V-0
- mechanical life: ≥ 500 cycles
- contact resistance: $\leq 3 \text{ m}\Omega$
- for max. current load see the connector inserts derating diagram below; for more information see page 28

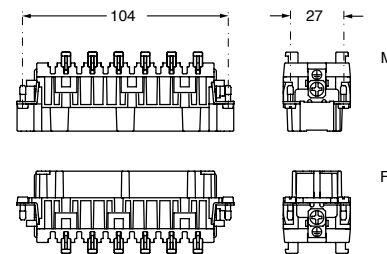

contacts side (front view)

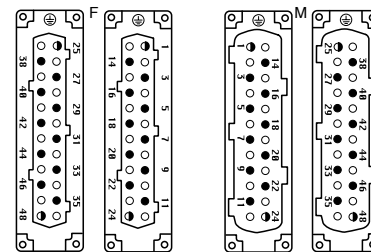

the auxiliary contacts are in the forward position upon opening

- inserts for section conductors: 0,14 - 2,5 mm² - AWG 26 - 14
- conductors stripping length: 9...11 mm

CMSh 20 poles connector inserts
Maximum current load derating diagram

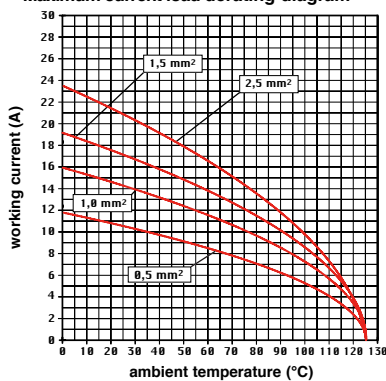

SQUICH®-spring connection technology

WIRING

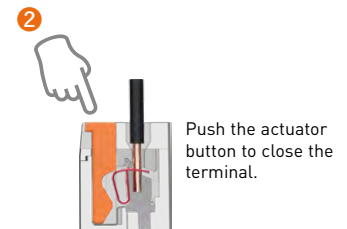
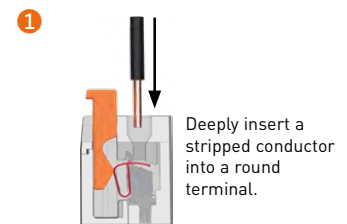

RE-OPENING

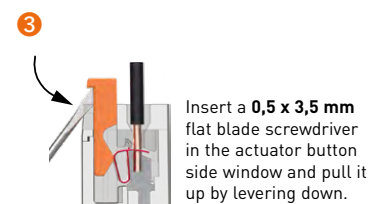

CMSh-SQUICH® 830V

CMCE 20 + 4 (aux) poles + ⊕ 16A - 830V

enclosures:
size "104.62"

page:

C-TYPE IP65/IP66	430
W-TYPE for aggressive environments	526
E-Xtreme® corrosion proof	547

inserts, crimp connections

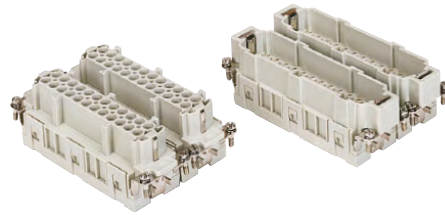

16A crimp contacts
standard or for advanced opening
silver and gold plated

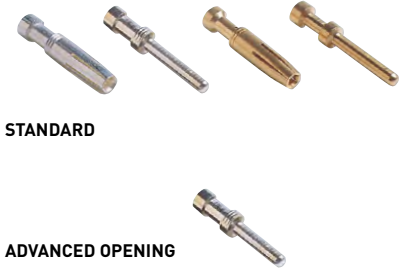

description	part No.	part No.	part No.
-------------	----------	----------	----------

without contacts (to be ordered separately)
female inserts for female contacts, No. (1-24) and (25-48)
male inserts for male contacts, No. (1-24) and (25-48)

CMCEF 10	CMCEF 10 N
CMCEM 10	CMCEM 10 N

16A female contacts

0,14-0,37 mm ²	AWG 26-22	one groove
0,5 mm ²	AWG 20	with no grooves
0,75 mm ²	AWG 18	one groove (back side)
1 mm ²	AWG 18	one groove
1,5 mm ²	AWG 16	two grooves
2,5 mm ²	AWG 14	three grooves
3 mm ²	AWG 12	one wide groove
4 mm ²	AWG 12	with no grooves

CCFA 0.3	CCFD 0.3
CCFA 0.5	CCFD 0.5
CCFA 0.7	CCFD 0.7
CCFA 1.0	CCFD 1.0
CCFA 1.5	CCFD 1.5
CCFA 2.5	CCFD 2.5
CCFA 3.0	CCFD 3.0
CCFA 4.0	CCFD 4.0

silver plated

gold plated+

16A male contacts

0,14-0,37 mm ²	AWG 26-22	one groove
0,5 mm ²	AWG 20	with no grooves
0,75 mm ²	AWG 18	one groove (back side)
1 mm ²	AWG 18	one groove
1,5 mm ²	AWG 16	two grooves
2,5 mm ²	AWG 14	three grooves
3 mm ²	AWG 12	one wide groove
4 mm ²	AWG 12	with no grooves

CCMA 0.3	CCMD 0.3
CCMA 0.5	CCMD 0.5
CCMA 0.7	CCMD 0.7
CCMA 1.0	CCMD 1.0
CCMA 1.5	CCMD 1.5
CCMA 2.5	CCMD 2.5
CCMA 3.0	CCMD 3.0
CCMA 4.0	CCMD 4.0

16A male crimp contacts for advanced opening

0,5 mm ²	AWG 20	with no grooves
0,75 mm ²	AWG 18	one groove (back side)
1 mm ²	AWG 18	one groove
1,5 mm ²	AWG 16	two grooves
2,5 mm ²	AWG 14	three grooves

CC 0.5 AN
CC 0.7 AN
CC 1.0 AN
CC 1.5 AN
CC 2.5 AN

* for basic or high thickness gold plating, please refer to page 675

- characteristics according to EN 61984:

- 16A 830V 8kV 3
- 16A 1000V 8kV 2
- 16A 720/1250V 8kV 2
- auxiliary contacts: 16A 500V 6kV 3

- certified

- rated voltage according to UL/CSA: 600V
- insulation resistance: ≥ 10 GΩ
- ambient temperature limit: -40 °C ... +125 °C
- made of self-extinguishing thermoplastic resin UL 94V-0
- mechanical life: ≥ 500 cycles
- contact resistance: ≤ 1 mΩ
- for max. current load see the connector inserts derating diagram below; for more information see page 28

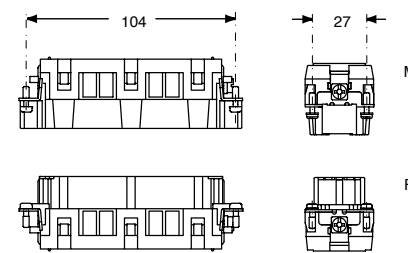

contacts side (front view)

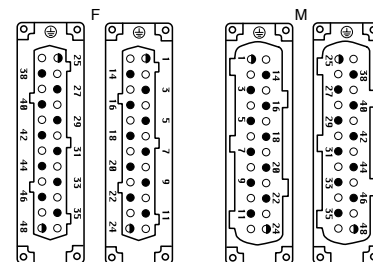

● the auxiliary contacts are in the forward position upon opening

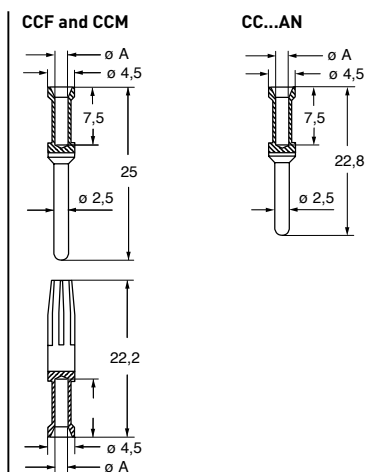

CCF, CCM and CC...AN contacts

conductor section mm ²	conductor slot ø A (mm)	conductors stripping length (mm)
0,14-0,37	0,9	7,5
0,5	1,1	7,5
0,75	1,3	7,5
1,0	1,45	7,5
1,5	1,8	7,5
2,5	2,2	7,5
3	2,55	7,5
4	2,85	7,5

CMCE 20 poles connector inserts
Maximum current load derating diagram

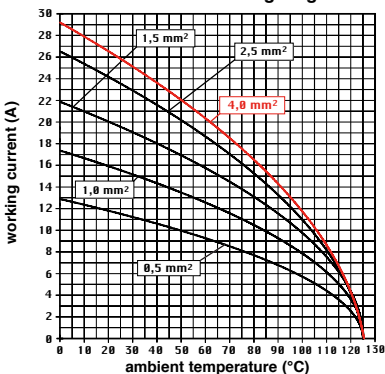

- it is recommended to crimp the contacts with crimping tools homologated by ILME (please see the crimping tool section 16A contacts, CCF, CCM and CC...AN series on pages 708 - 741)